

Standards and certifications Parameters related to the environment

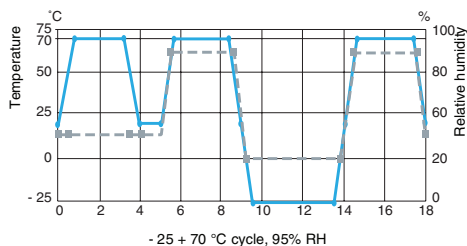

— Temperature °C
- - Humidity as %

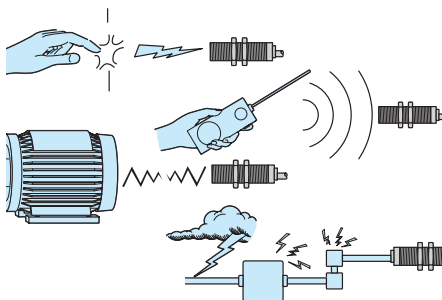

Insulation

Recommendations

The sensors detailed in this catalogue are designed for use in standard industrial applications relating to presence detection. These sensors do not incorporate the required redundant electrical circuit enabling their usage in safety applications. For safety applications, please refer to our "Safety solutions using Preventa" catalogue.

Quality control

Our inductive proximity sensors are subject to special precautions in order to guarantee their reliability in the most arduous industrial environments.

■ Qualification

- The product characteristics stated in this catalogue are subject to a **qualification procedure** carried out in our laboratories.
- In particular, the products are subjected to **climatic cycle** tests for 3000 hours whilst powered-up to verify their ability to maintain their characteristics over time.

■ Production

- The electrical characteristics and sensing distances at both ambient temperature and extreme temperatures are 100% checked.
- Products are randomly selected during the course of production and subjected to **monitoring tests** relating to all their qualified characteristics.

■ Customer returns

If, in spite of all these precautions, defective products are returned to us, they are subject to **systematic analysis** and **corrective actions** are implemented to eliminate the risks of the fault recurring.

Conformity to standards

All Telemecanique brand inductive proximity sensors conform to and are tested in accordance with the recommendations of standard IEC 60947-5-2.

Mechanical shock resistance

The sensors are tested in accordance with standard IEC 60068-2-27, 50 gn, duration 11 ms.

Vibration resistance

The sensors are tested in accordance with standard IEC 60068-2-6, amplitude ± 2 mm, f = 10...55 Hz, 25 gn at 55 Hz.

Resistance to the environment

- Please refer to the characteristics pages for the various sensors.
- **IP 67:** protection against the effects of immersion. Test conforming to IEC 60529: sensor immersed for 30 minutes in 1 m of water. No deterioration in either operating or insulation characteristics is permitted.
- **IP 68:** protection against prolonged immersion. Sensor immersed for 336 hours in 40 metres of water at 50 °C. No deterioration in either operating or insulation characteristics is permitted. Telemecanique sensors with an IP 68 degree of protection are ideal for use in the most arduous conditions, such as machine tools, automatic car washers.

Resistance to electromagnetic interference

- Electrostatic discharges ~ and ≈ versions: level 4 immunity (15 kV). **IEC 61000-4-2**
- Radiated electromagnetic fields (electromagnetic waves) ∴, ~ and ≈ versions: level 2 (3 V/m) or level 3 (10 V/m) immunity. **IEC 61000-4-3**
- Fast transients (motor start/stop interference) ∴ version: level 3 immunity (1 kV). ~ and ≈ versions: level 4 immunity (2 kV) except Ø 8 mm model (level 2). **IEC 61000-4-4**
- Impulse voltage ∴, ~ and ≈ versions: level 3 immunity (2.5 kV) except Ø 8 mm and smaller models (level 1 kV). **IEC 60947-5-2**

Resistance to chemicals in the environment

- Owing to the very wide range of chemicals encountered in industry, it is very difficult to give general guidelines common to all sensors.
 - To ensure lasting efficient operation, it is essential that any chemicals coming into contact with the sensors will not affect their casing and, in doing so, prevent their reliable operation.
 - Cylindrical and flat plastic case sensors offer excellent overall resistance to:
 - chemical products such as salts, aliphatic and aromatic oils, petroleum, acids and diluted bases. For alcohols, ketones and phenols, preliminary tests should be made relating to the nature and concentration of the liquid.
 - food and beverage industry products such as animal or vegetable based products (vegetable oils, animal fat, fruit juice, dairy proteins, etc.).
- In all cases, the materials selected (see product characteristics) provide satisfactory compatibility in most industrial environments (for further information, please consult your Regional Sales Office).

Class 2 devices

Electrical insulation conforming to standards IEC 61140 and NF C 20-030 relating to means of protection against electric shock.

Principle of inductive detection

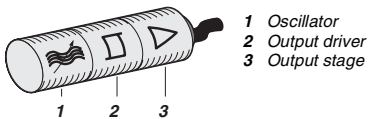

Composition of an inductive proximity sensor

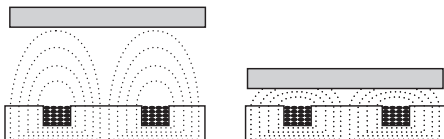

Detection of a metal object

Operating principle

■ An inductive proximity sensor is solely for the detection of metal objects. It basically comprises an oscillator whose windings constitute the sensing face. An alternating magnetic field is generated in front of these windings.

■ When a metal object is placed within the magnetic field generated by the sensor, the resulting currents induced form an additional load and the oscillations cease. This causes the output driver to operate and, depending on the sensor type, a normally open (NO) or normally closed (NC) output signal is produced.

Inductive proximity detection

- Inductive proximity sensors enable the detection, without physical contact, of metal objects.
- Their range of applications is very extensive and includes:
 - monitoring the position of machine parts (cams, end stops, etc.),
 - counting the presence of metal objects, etc.

Advantages of inductive detection

- No physical contact with the object to be detected, thus avoiding wear and enabling detection of fragile objects, freshly painted objects, etc.
- High operating rates. Fast response.
- Excellent resistance to industrial environments (robust products, fully encapsulated in resin).
- Solid-state technology: no moving parts, therefore service life of sensor not related to number of operating cycles.

Osiconcept

■ **Osiconcept** sensors are suitable for all metal environments (flush mountable or non flush mountable) since they ensure a maximum sensing distance, even if there is a metal background. Precise detection of the position of the object can be obtained using the teach mode. For further information, see pages 2/20 and 2/21.

LED indicator

	NO output	NC output
No object present	LED Output state	LED Output state
Object present	LED Output state	LED Output state

Output LED

All Telemecanique brand inductive proximity sensors incorporate an output state LED indicator. **Osiconcept** sensors are fitted with a green LED that indicates "Power on" and also assists the user during setting-up (teach mode).

Mounting sensors on a metal support

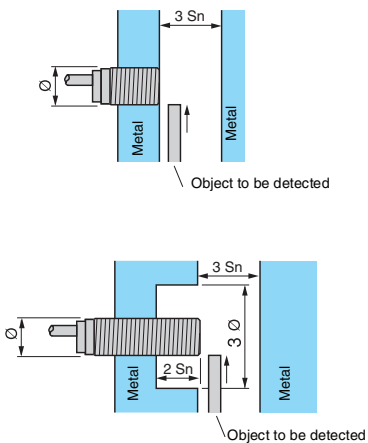

Sensors suitable for flush mounting in metal

- No side clearance required.
- All models using the **Osiconcept** system are flush mountable in metal without reducing the sensing distance and also enable the detection of an object against a metal background. For further information, see pages 2/20 and 2/21.

Sensors not suitable for flush mounting in metal

- Side clearance required. Sensing distance greater than that for a standard flush mountable model.
- The **Osiconcept** system eliminates the side clearance requirement. For further information, see pages 2/20 and 2/21.

2

Mounting sensors on a metal support

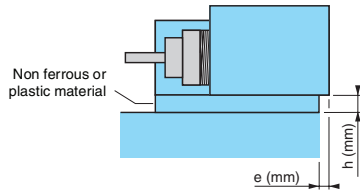

Mounting distance between sensors

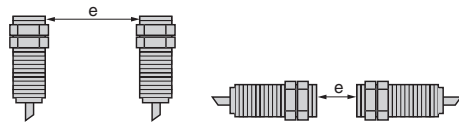

Mounting side by side
 $e \geq 2 S_n$

Mounting face to face
 $e \geq 10 S_n$

Tightening torque for cylindrical type sensors

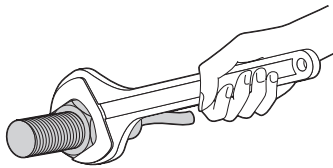

Mounting using fixing clamp

- Standard flush mountable models: $e = 0, h = 0$
- Standard non flush mountable models:
 - $\varnothing 6.5 / 8 / 12$ mm: $e = 0, h = 0,$
 - $\varnothing 18$ mm: if $h = 0, e \geq 5; e = 0, h \geq 3,$
 - $\varnothing 30$ mm: if $h = 0, e \geq 8; e = 0, h \geq 4.$
- Osiconcept models: $e = 0, h = 0$

Standard sensors

If 2 standard sensors are mounted too close to each other they are likely to lock in the "detection state" due to interference between their respective oscillating frequencies. To avoid this condition, minimum mounting distances stated for the sensors should be adhered to or, alternatively, sensors with staggered oscillating frequencies should be used.

Staggered frequency sensors

For applications where the minimum recommended mounting distances for standard sensors cannot be achieved, it is possible to overcome this restraint by using staggered frequency sensors. Please consult your Regional Sales Office. In this case, a staggered frequency sensor is mounted adjacent to or opposite each standard sensor.

Diameter of sensor (mm)	Maximum tightening torque for the various sensor case materials			
	Brass	Brass	Stainless steel	Plastic
	Short case model XS5 ●●B1	Form A model XS6 ●●B1 XS6 ●●B2 XSA V●	Form A model XS1 ●● XS2 ●●	All models XS4 P●●
Ø 5	1.6 N.m	1.6 N.m	2 N.m	–
Ø 8	5 N.m	5 N.m	9 N.m	1 N.m
Ø 12	6 N.m	15 N.m	30 N.m	2 N.m
Ø 18	15 N.m	35 N.m	50 N.m	5 N.m
Ø 30	40 N.m	50 N.m	100 N.m	20 N.m

Sensing distance

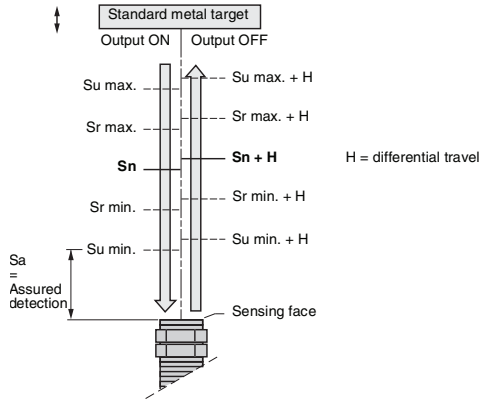

Definitions

In order to ensure that customers can make reliable product comparisons and selection, the standard IEC 60947-5-2 defines various sensing distances, such as:

■ **Nominal sensing distance (Sn)**

The rated operating distance for which the sensor is designed. It does not take into account any variations (manufacturing tolerances, temperature, voltage).

■ **Real sensing distance (Sr)**

The real sensing distance is measured at the rated voltage (U_n) and the rated ambient temperature (T_n).

It must be between 90% and 110% of the nominal sensing distance (S_n): $0.9 S_n \leq S_r \leq 1.1 S_n$.

■ **Usable sensing distance (Su)**

The usable sensing distance is measured at the limits of the permissible variations in the ambient temperature (T_a) and the supply voltage (U_b). It must be between 90% and 110% of the real sensing distance: $0.9 S_r \leq S_u \leq 1.1 S_r$.

■ **Assured sensing distance (Sa)**

This is the operating zone of the sensor. The assured operating distance is between 0 and 81% of the nominal sensing distance (S_n): $0 \leq S_a \leq 0.9 \times 0.9 \times S_n$

Standard metal target

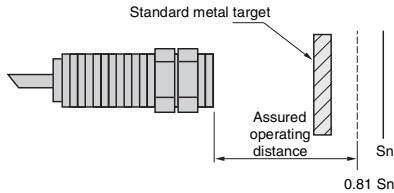

The standard IEC 60947-5-2 defines the standard metal target as a square mild steel (Fe 360) plate, 1 mm thick.

The side dimension of the plate is either equal to the diameter of the circle engraved on the sensing face of the sensor or 3 times the nominal sensing distance (S_n).

Terminology

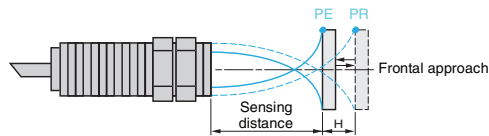

PE = pick-up point, the target is detected
PR = drop-out point, the target is no longer detected

Differential travel

The differential travel (H), or hysteresis, is the distance between the pick-up point, as the standard metal target moves towards the sensor, and the drop-out point, as it moves away. This hysteresis is essential for the stable operation of the sensor.

Repeat accuracy

The repeat accuracy (R) is the repeatability of the sensing distance between successive operations. Readings are taken over a period of time whilst the sensor is subjected to voltage and temperature variations: 8 hours, 10 to 30 °C, $U_n \pm 5\%$. It is expressed as a percentage of S_r .

Detection zone and precision adjustment zone

■ By using sensitivity adjustment in teach mode, Osiconcept proximity sensors enable the position of an object to be detected as it approaches from the front or side. The teach mode can be used when the object is located in the zone known as the "precision adjustment zone". When the object approaches from the front, the detection zone of the object ranges from the stored position down to zero.

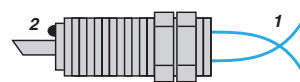
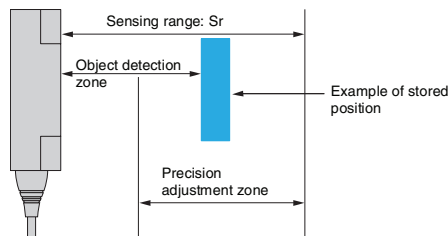

1 Detection threshold curves
2 "Object detected" LED

Operating zone

■ The operating zone relates to the area in front of the sensing face in which the detection of a metal object is certain.

The values stated in the characteristics relating to the various types of sensor are for steel objects of a size equal to the sensing face of the sensor.

For objects of a different nature (smaller than the sensing face of the sensor, other metals, etc.), it is necessary to apply a correction coefficient.

2

Correction coefficients to apply to the assured operating distance

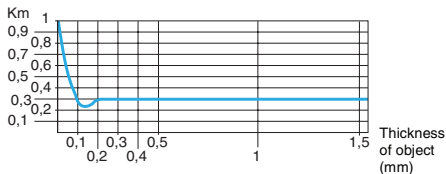
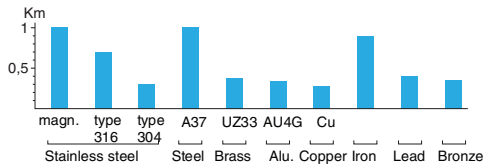
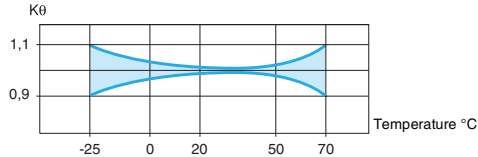

Typical curve for a **copper** object used with a Ø 18 mm cylindrical sensor

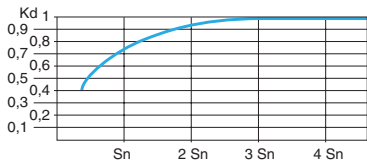

Typical curve for a **steel** object used with a Ø 18 mm cylindrical sensor

Calculation examples

Assured operating distance of a sensor

In practice, most objects to be detected are generally made of steel and are of a size equal to, or greater, than the sensing face of the sensor.

For the calculation of the assured operating distance for different operating conditions, one must take into account the correction coefficients that influence it.

The curves indicated are purely representative of typical curves. They are only given as a guide to the approximate usable sensing distance of a proximity sensor for a given application.

Influence of ambient temperature

Apply a correction coefficient K_{θ} , determined from the curve shown opposite.

Material of object to be detected

Apply a correction coefficient K_m , determined from the diagram shown opposite.

The fixed sensing distance models for ferrous/non ferrous (Fe/NFe) materials enable the detection of different objects at a fixed distance, irrespective of the type of material.

Special case of a very thin object made of a non ferrous material.

Size of object to be detected

Apply a correction coefficient K_d , determined from the curve shown opposite. When calculating the sensing distance for the selection of a sensor, make the assumption that $K_d = 1$.

Variation of supply voltage

In all cases, apply the correction coefficient $K_t = 0.9$.

Correction of the sensing distance of a sensor

Sensor with nominal sensing distance $S_n = 15$ mm.
 Ambient temperature variation 0 to +20 °C.
 Object material and size: steel, 30 x 30 x 1 mm thick.
 The assured operating distance S_a is determined using the formula:
 $S_a = S_n \times K_{\theta} \times K_m \times K_d \times K_t = 15 \times 0.98 \times 1 \times 0.95 \times 0.9$
 i.e. $S_a = 12.5$ mm.

Selecting a sensor for a given application

Application characteristics:
 - object material and size: iron ($K_m = 0.9$), 30 x 30 mm,
 - temperature: 0 to 20 °C ($K_{\theta} = 0.98$),
 - object detection distance: 3 mm ± 1.5 mm, i.e. $S_a \text{ max.} = 4.5$ mm,
 - assume $K_d = 1$.
 A sensor must be selected for which $S_n \geq \frac{S_a}{K_{\theta} \times K_m \times K_d \times K_t} = \frac{4.5}{0.98 \times 0.9 \times 1 \times 0.9}$
 i.e. $S_n \geq 5.7$ mm

Specific aspects of electronic sensors

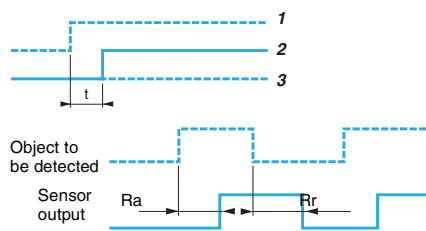
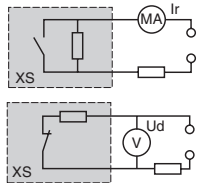

Terminology

- Residual current (I_r)
 - The residual current (I_r) corresponds to the current flowing through the sensor when in the "open" state.
 - Characteristic of 2-wire type proximity sensors.
- Voltage drop (U_d)
 - The voltage drop (U_d) corresponds to the voltage drop at the sensor's terminals when in the "closed" state (value measured at nominal current rating of sensor).
- First-up delay
 - The first-up delay corresponds to the time (t) between the connection of the power supply to the sensor and its fully operational state.
 - 1 Supply voltage U on
 - 2 Sensor operational at state 1
 - 3 Sensor at state 0
- Delays
 - Response time (R_a): the time delay between the object to be detected entering the sensor's operating zone and the subsequent change of output state. This parameter limits the speed and size of the object.
 - Recovery time (R_r): the time delay between an object to be detected leaving the sensor's operating zone and the subsequent change of output state. This parameter limits the interval between successive objects.

Power supply

Sensors for a.c. circuits (\sim and \approx models)

Check that the voltage limits of the sensor are compatible with the nominal voltage of the a.c. supply used.

Sensors for d.c. circuits

- **d.c. source:** check that the voltage limits of the sensor and the acceptable level of ripple are compatible with the supply used.
- **a.c. source** (comprising transformer, rectifier, smoothing capacitor): the supply voltage must be within the operating limits specified for the sensor.

Where the voltage is derived from a single-phase a.c. supply, the voltage must be rectified and smoothed to ensure that:

- the peak voltage of the d.c. supply is lower than the maximum voltage rating of the sensor.
 - Peak voltage = nominal voltage $\times \sqrt{2}$
 - the minimum voltage of the supply is greater than the minimum voltage rating of the sensor, given that:
 - $\Delta V = (I \times t) / C$,
 - $\Delta V = \text{max. ripple: } 10\% (V)$,
 - $I = \text{anticipated load current (mA)}$,
 - $t = \text{period of 1 cycle (10 ms full-wave rectified for a 50 Hz supply frequency)}$,
 - $C = \text{capacitance } (\mu F)$.
- As a general rule, use a transformer with a lower secondary voltage (U_e) than the required d.c. voltage (U).

Example:
 $\sim 18\text{ V}$ to obtain $\text{---} 24\text{ V}$,
 $\sim 36\text{ V}$ to obtain $\text{---} 48\text{ V}$.

Outputs

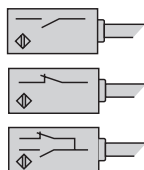

Output signal (contact logic)

- Normally open (NO)
 - Corresponds to a sensor whose output changes to the closed state when an object is present in the operating zone.
- Normally closed (NC)
 - Corresponds to a sensor whose output changes to the open state when an object is present in the operating zone.
- Complementary outputs (NO + NC)
 - Corresponds to a sensor with a normally closed output and a normally open output.

Outputs (continued)

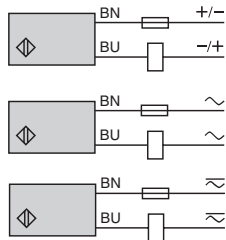

2-wire type $\overline{\text{---}}$, non polarised NO or NC output

■ **Specific aspects**

These sensors are wired in series with the load to be switched.

As a consequence, they are subject to:

- a residual current in the open state (current flowing through the sensor in the "open" state),
- a voltage drop in the closed state (voltage drop across the sensor's terminals in the "closed" state).

■ **Advantages**

- Only 2 leads to be wired: these sensors can be wired in series in the same way as mechanical limit switches,
- They can be connected to either positive (PNP) or negative (NPN) logic PLC inputs,
- No risk of incorrect connections.

■ **Operating precautions**

- Check the possible effects of residual current and voltage drop on the actuator or input connected,
- For sensors that do not have overload and short-circuit protection (a.c. or a.c./d.c. symbol), it is essential to connect a 0.4 A "quick-blow" fuse in series with the load.

3-wire type $\overline{\text{---}}$, NO or NC output, PNP or NPN

■ **Specific aspects**

These sensors comprise 2 wires for the d.c. supply and a 3rd wire for the output signal,

- PNP type: switching the positive side to the load,
- NPN type: switching the negative side to the load.

■ **Advantages**

- Protection against supply reverse polarity,
- Protection against overload and short-circuit,
- No residual current, low voltage drop.

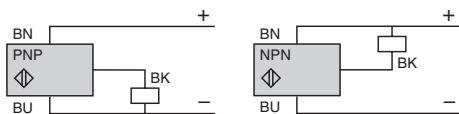

4-wire type, complementary outputs $\overline{\text{---}}$, NO and NC outputs, PNP or NPN

■ **Advantages**

- Protection against supply reverse polarity (+/-).
- Protection against overload and short-circuit.

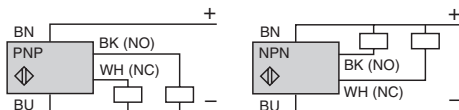

4-wire type, multifunction, programmable $\overline{\text{---}}$, NO or NC output, PNP or NPN

■ **Advantages**

- Protection against supply reverse polarity (+/-).
- Protection against overload and short-circuit.

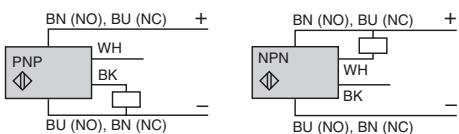

Specific output signals, analogue type

■ These sensors convert the approach of a metal object towards the sensing face into an output current variation which is proportional to the distance between the object and the sensing face.

- Two models available:
 - 0...10 V (0...10 mA) output for 3-wire connection,
 - 4-20 mA output for 2-wire connection.

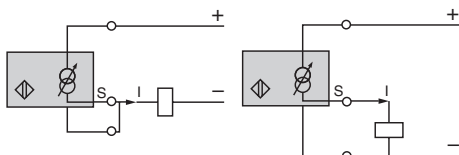

2-wire connection

3-wire connection

Features of the various models

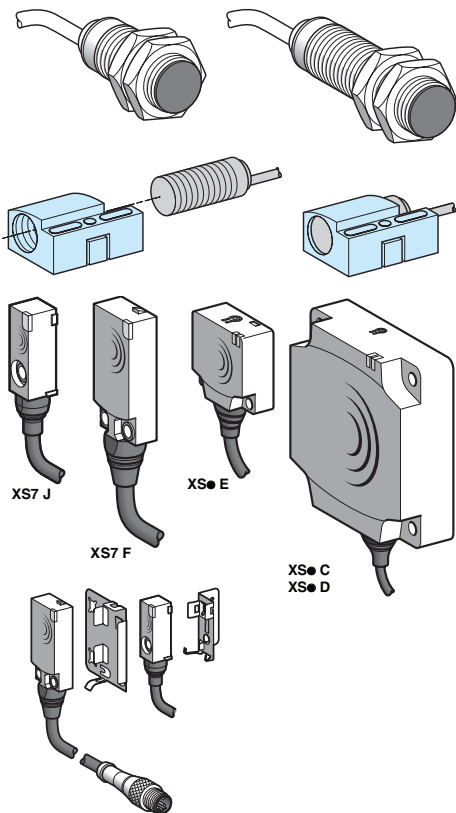

Types of case

- **Cylindrical case**
 - Fast installation and setting-up.
 - Pre-cabled and connector versions.
 - Small size facilitates mounting in locations with restricted access.
 - **Interchangeability**, provided by indexed **fixing clamp**: when assembled, becomes similar to a block type sensor.

- **Flat case**
 - Reduced size (sensor volume divided by 8).
 - Fast installation by mounting on clip-on brackets.
 - Precision detection using **Osiconcept** teach mode.

Electrical connection

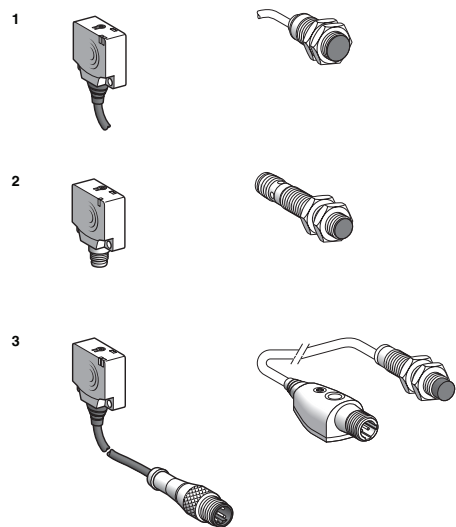

Connection methods

- 1 Pre-cabled:** factory fitted moulded cable, good protection against splashing liquids (IP 68). Example: machine tool.
- 2 Connector:** easy installation and maintenance (IP 67).
- 3 Remote connector:** easy installation and maintenance (IP 68 at sensor level and IP 67 at remote connector level).

Wiring advice

- **Length of cable**
 - No limitation up to 200 m or up to a line capacitance of < 100 nF (characteristics of sensor remain unaffected).
 - In this case, it is important to take into account the voltage drop on the line.
- **Separation of control and power circuit wiring**
 - The sensors are immune to electrical interference encountered in normal industrial conditions.
 - Where extreme conditions of electrical "noise" could occur (large motors, spot welders, etc.), it is advisable to protect against transients in the normal way:
 - suppress interference at source,
 - separate power and control wiring from each other,
 - smooth the supply,
 - limit the length of cable.
- **Connect the sensor with supply switched off.**

Setting-up precautions

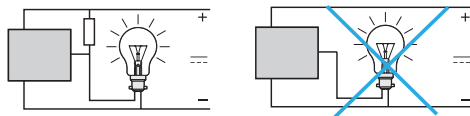
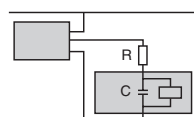
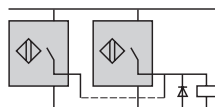
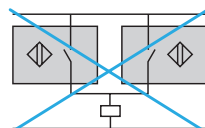
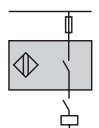
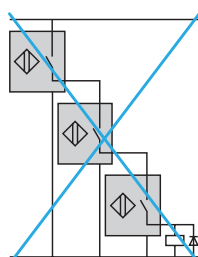
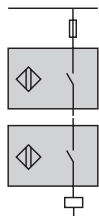

Connection in series

2-wire type sensors

- The following points should be taken into account:
 - Series wiring is only possible using sensors with wide voltage limits.
- Based on the assumption that each sensor has the same residual current value, each sensor, in the open state, will share the supply voltage, i.e.

$$U_{\text{sensor}} = \frac{U_{\text{supply}}}{n \text{ sensors}}$$

- U sensor and U supply must remain within the sensor's voltage limits.
- If only one sensor in the circuit is in the open state, it will be supplied at a voltage almost equal to the supply voltage.
- When in the closed state, a small voltage drop is present across each sensor. The resultant loss of voltage at the load will be the sum of the individual voltage drops and therefore, the load voltage should be selected accordingly.

3-wire type sensors

This connection method is not recommended.

- Correct operation of the sensors cannot be assured and, if this method is used, tests should be made before installation.
- The following points should be taken into account:
- Sensor 1 carries the load current in addition to the no-load current consumption values of the other sensors connected in series. For certain models, this connection method is not possible unless a current limiting resistor is used.
 - When in the closed state, a small voltage drop is present across each sensor. The load should therefore be selected accordingly.
 - As sensor 1 closes, sensor 2 does not operate until a certain time (t) has elapsed (corresponding to the first-up delay) and likewise for the following sensors in the sequence.
 - The use of "flywheel" diodes is recommended when an inductive load is being switched.

Sensors and devices in series with an external mechanical contact

2 and 3-wire type sensors

- The following points should be taken into account:
 - When the mechanical contact is open, the sensor is not supplied.
 - When the contact closes, the sensor does not operate until a certain time (t) has elapsed (corresponding to the first-up delay).

Connection in parallel

2-wire type sensors

This connection method is not recommended.

- Should one of the sensors be in the closed state, the sensor in parallel will be "shorted-out" and no longer supplied.
- As the first sensor passes into the open state, the second sensor will become energised and will be subject to its first-up delay.
- This configuration is only permissible where the sensors will be working alternately.
 - This method of connection can lead to irreversible damage of the units.

3-wire type sensors

- No specific restrictions. The use of "flywheel" diodes is recommended when an inductive load (relay) is being switched.

a.c. supply

- **2-wire type sensors cannot be connected directly to an a.c. supply.**
 - This would result in immediate destruction of the sensor and considerable danger to the user.
 - An appropriate load (refer to the instruction sheet supplied with the sensor) must always be connected in series with the sensor.

Capacitive load (C > 0.1 μF)

- On power-up, it is necessary to limit (by resistor) the charging current of the capacitive load C.
- The voltage drop in the sensor can also be taken into account by subtracting it from the supply voltage for the calculation of R.

$$R = \frac{U_{\text{supply}}}{I_{\text{max. (sensor)}}$$

Load comprising an incandescent lamp

- If the load comprises an incandescent lamp, the cold state resistance can be 10 times lower than the hot state resistance. This can cause very high current levels on switching. Fit a pre-heater resistor in parallel with the sensor.

$$R = \frac{U^2}{P} \times 10, \quad U = \text{supply voltage and } P = \text{lamp power}$$

Fast troubleshooting guide			
Problem	Possible causes	Remedy	
The sensor's output will not change state when a metal object enters the detection zone	On an Osiconcept sensor: setting-up or programming error.	<ul style="list-style-type: none"> ■ After a RESET, follow the environment teach mode procedure. Refer to instruction sheet supplied with sensor. 	
	Output stage faulty or complete failure of the sensor or the short-circuit protection has tripped.	<ul style="list-style-type: none"> ■ Check that the sensor is compatible with the supply being used. ■ Check the load current characteristics: <ul style="list-style-type: none"> □ if load current $I \geq$ maximum switching capacity, an auxiliary relay, of the CAD N type for example, should be interposed between the sensor and the load, □ if $I \leq$ maximum switching capacity, check for wiring faults (short-circuit). ■ In all cases, a 0.4 A "quick-blow" fuse should be fitted in series with the sensor. 	
	Wiring error	<ul style="list-style-type: none"> ■ Check that the wiring conforms to the wiring shown on the sensor label or instruction sheet. 	
	Supply fault	<ul style="list-style-type: none"> ■ Check that the sensor is compatible with the supply (\sim or $---$). ■ Check that the supply voltage is within the voltage limits of the sensor. Remember that with a rectified, smoothed supply, $U_{peak} = U_{nominal} \times \sqrt{2}$ with a ripple voltage $\leq 10\%$. 	
	False or erratic operation, with or without the presence of a metal object in the detection zone	On an Osiconcept sensor: setting-up or programming error.	<ul style="list-style-type: none"> ■ After a RESET, follow the environment teach mode procedure. Refer to instruction sheet supplied with sensor.
	Influence of background or metal environment	<ul style="list-style-type: none"> ■ Refer to the instruction sheet supplied with the sensor. For sensors with adjustable sensitivity, reduce the sensing distance. 	
False or erratic operation, with or without the presence of a metal object in the detection zone	Operating distance poorly defined for the object to be detected	<ul style="list-style-type: none"> ■ Apply the correction coefficients. ■ Realign the system or run the teach mode again. 	
	Influence of transient interference on the supply lines	<ul style="list-style-type: none"> ■ Ensure that any d.c. supplies, when derived from rectified a.c., are correctly smoothed ($C > 400 \mu F$). ■ Separate a.c. power cables from low-level d.c. cables (24 V low level). ■ Where very long distances are involved, use suitable cable: screened and twisted pairs of the correct cross-sectional area. 	
	Equipment prone to emitting electromagnetic interference	<ul style="list-style-type: none"> ■ Position the sensors as far away as possible from any sources of interference. 	
	Response time of the sensor too slow for the particular object being detected	<ul style="list-style-type: none"> ■ Check the suitability of the sensor for the position or size of the object to be detected. ■ If necessary, select a sensor with a higher switching frequency. 	
	Influence of high temperature	<ul style="list-style-type: none"> ■ Eliminate sources of radiated heat or protect the sensor casing with a heat shield. ■ Realign, having adjusted the temperature around the fixing support. 	
	No detection following a period of service	Vibration, shock	<ul style="list-style-type: none"> ■ Realign the system. ■ Replace the support or protect the sensor.

Inductive proximity sensors

Osiprox®

Osiconcept®: Offering Simplicity through Innovation

2

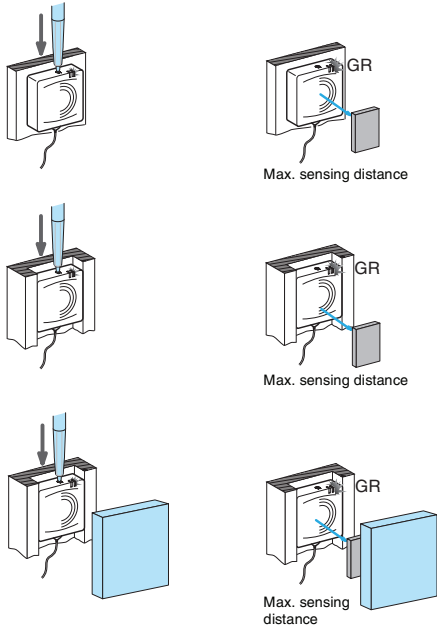

Operating principle

In proposing the **Osiconcept** technology, Telemecanique brand offers simplicity through innovation.

- With **Osiconcept**, a single product meets all metal object detection needs. By simply pressing the “Teach mode” pushbutton, the product automatically takes up an optimum configuration for all detection, flush mountability and environment requirements.

- Other advantages of **Osiconcept**:

- Increased performance:

- sensing distance guaranteed and optimized irrespective of the mounting configuration, the object, the environment or the background,
- suitable for all metal environments.

- Simplified use provided by:

- the **Osiconcept** technology associated with the availability of the flattest, most compact sensors on the market ensuring that the sensor is fully built into the machine, thereby limiting risks of mechanical damage,
- mechanical adjustments being eliminated through the use of the teach mode.

- Lower costs due to:

- adjustment times and complex supports being eliminated,
- the elimination of flush mountable and non flush mountable versions which halves the number of references,
- much easier and much quicker product selection.

Precision position detection

All **Osiconcept** inductive proximity sensors benefit from ultra precise adjustment which is very quick irrespective of the metal environment.

- Precision side approach detection makes it possible to accurately define the position at which the object will be detected as it passes the sensor. Due to the **Osiconcept** technology, the desired detection position can be stored in memory by simply pressing the teach button.

- Precision frontal approach detection makes it possible to accurately define the position at which the object will be detected as it approaches the sensor. Due to the **Osiconcept** technology, the desired detection position can be stored in memory by simply pressing the teach button.

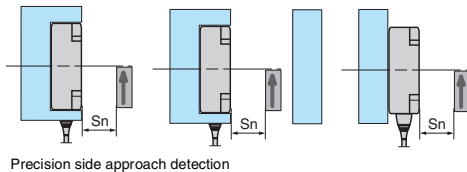

Precision side approach detection

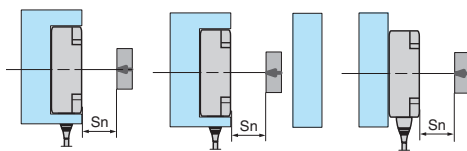

Precision frontal approach detection

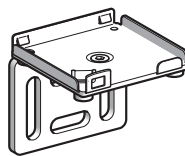
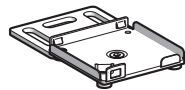

Mounting accessories

Telemecanique brand proposes a complete, inexpensive range of mounting accessories (clamps, plates, brackets, etc.) providing solutions to all setting-up problems.

- Fixing kits enable quick installation or replacement of **Osiconcept** sensors.

- No adjustment is required. Simple clipping-in enables the sensor to be fixed in position and ready for operation.



Block type				
Dimensions (mm)		26 x 26 x 13	40 x 40 x 15	80 x 80 x 26
Sensing distance (mm)	Flush mounted use	0...10	0...15	0...40
	Non flush mounted use	0...15	0...25	0...60
Sensor type		XS8 E1A1	XS8 C1A1	XS8 D1A1
Page		2/30		



Cylindrical type				
Dimensions (mm)		12	18	30
Sensing distance (mm)	Flush mounted use	0...3.4	0...6	0...11
	Non flush mounted use	0...5	0...9	0...18
Sensor type		XS6 12B2	XS6 18B2	XS6 30B2
Page		2/58		

Inductive proximity sensors

Osiprox® Universal
Cylindrical, flush mountable

Three-wire, d.c. supply, solid-state output

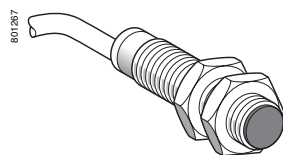

XS6 ●●B1●●L2

2

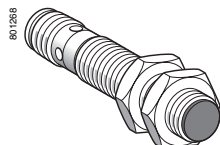

XS6 ●●B1●●M12

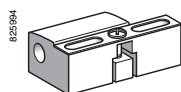

XSZ B●●●

Ø 8, threaded M8 x 1

Sensing distance (Sn) mm	Function	Output	Connection	Reference	Weight kg
2.5	NO	PNP	Pre-cabled (L = 2 m) (1)	XS6 08B1PAL2	0.035
			M12 connector	XS6 08B1PAM12	0.015
		NPN	Pre-cabled (L = 2 m) (1)	XS6 08B1NAL2	0.035
			M12 connector	XS6 08B1NAM12	0.015
	NC	PNP	Pre-cabled (L = 2 m) (1)	XS6 08B1PBL2	0.035
			M12 connector	XS6 08B1PBM12	0.015
NPN		Pre-cabled (L = 2 m) (1)	XS6 08B1NBL2	0.035	
		M12 connector	XS6 08B1NBM12	0.015	

Ø 12, threaded M12 x 1

Sensing distance (Sn) mm	Function	Output	Connection	Reference	Weight kg
4	NO	PNP	Pre-cabled (L = 2 m) (1)	XS6 12B1PAL2	0.075
			M12 connector	XS6 12B1PAM12	0.020
		NPN	Pre-cabled (L = 2 m) (1)	XS6 12B1NAL2	0.075
			M12 connector	XS6 12B1NAM12	0.020
	NC	PNP	Pre-cabled (L = 2 m) (1)	XS6 12B1PBL2	0.075
			M12 connector	XS6 12B1PBM12	0.020
NPN		Pre-cabled (L = 2 m) (1)	XS6 12B1NBL2	0.075	
		M12 connector	XS6 12B1NBM12	0.020	

Ø 18, threaded M18 x 1

Sensing distance (Sn) mm	Function	Output	Connection	Reference	Weight kg
8	NO	PNP	Pre-cabled (L = 2 m) (1)	XS6 18B1PAL2	0.100
			M12 connector	XS6 18B1PAM12	0.040
		NPN	Pre-cabled (L = 2 m) (1)	XS6 18B1NAL2	0.100
			M12 connector	XS6 18B1NAM12	0.040
	NC	PNP	Pre-cabled (L = 2 m) (1)	XS6 18B1PBL2	0.100
			M12 connector	XS6 18B1PBM12	0.040
NPN		Pre-cabled (L = 2 m) (1)	XS6 18B1NBL2	0.100	
		M12 connector	XS6 18B1NBM12	0.040	

Ø 30, threaded M30 x 1.5

Sensing distance (Sn) mm	Function	Output	Connection	Reference	Weight kg
15	NO	PNP	Pre-cabled (L = 2 m) (1)	XS6 30B1PAL2	0.205
			M12 connector	XS6 30B1PAM12	0.145
		NPN	Pre-cabled (L = 2 m) (1)	XS6 30B1NAL2	0.205
			M12 connector	XS6 30B1NAM12	0.145
	NC	PNP	Pre-cabled (L = 2 m) (1)	XS6 30B1PBL2	0.205
			M12 connector	XS6 30B1PBM12	0.145
NPN		Pre-cabled (L = 2 m) (1)	XS6 30B1NBL2	0.205	
		M12 connector	XS6 30B1NBM12	0.145	

Accessories (2)

Description		Reference	Weight kg
Fixing clamps	Ø 8	XSZ B108	0.006
	Ø 12	XSZ B112	0.006
	Ø 18	XSZ B118	0.010
	Ø 30	XSZ B130	0.020

(1) For a 5 m long cable, replace L2 with L5, and for a 10 m long cable, replace L2 with L10.

Example: XS6 08B1PAL2 becomes **XS6 08B1PAL5** with a 5 m long cable.

(2) For further information, see page 2/102.

Inductive proximity sensors

Osiprox® Universal

Cylindrical, flush mountable

Three-wire, d.c. supply, solid-state output

Characteristics		XS6 ●●B1●●M12	XS6 ●●B1●●L2
Sensor type		UL, CSA, CE	
Product certifications		UL, CSA, CE	
Connection	Connector	M12	—
	Pre-cabled	—	Length: 2 m
Operating zone	Ø 8	mm	0...2
	Ø 12	mm	0...3.2
	Ø 18	mm	0...6.4
	Ø 30	mm	0...12
Differential travel	%	1...15 of real sensing distance (Sr)	
Degree of protection	Conforming to IEC 60529	IP 67	IP 68 double insulation □ (except Ø 8: IP 67)
Storage temperature range	°C	- 40...+ 85	
Operating temperature range	°C	- 25...+ 70	
Materials	Case	Nickel plated brass except XS6 08: stainless steel grade 303	
	Pre-cabled	—	PvR 3 x 0.34 mm ² (except XS6 08: 3 x 0.11 mm ²)
Vibration resistance	Conforming to IEC 60068-2-6	25 gn, amplitude ± 2 mm (f = 10 to 55 Hz)	
Shock resistance	Conforming to IEC 60068-2-27	50 gn, duration 11 ms	
Output state indication		LED (yellow), 4 viewing ports at 90°	LED (yellow), annular
Rated supply voltage	V	— 12...48 with protection against reverse polarity	
Voltage limits (including ripple)	V	— 10...58	
Switching capacity	mA	≤ 200 with overload and short-circuit protection	
Voltage drop, closed state	V	≤ 2	
Current consumption, no-load	mA	≤ 10	
Maximum switching frequency	XS6 08B1●●●●, XS6 12B1●●●●	Hz	2500
	XS6 18B1●●●●	Hz	1000
	XS6 30B1●●●●	Hz	500
Delays	First-up	ms	≤ 10
	Response	ms	≤ 0.2 for Ø8 and Ø12, ≤ 0.3 for Ø18, ≤ 0.6 for Ø30
	Recovery	ms	≤ 0.2 for Ø8 and Ø12, ≤ 0.7 for Ø18, ≤ 1.4 for Ø30

Wiring scheme

Connector	Pre-cabled	PNP	NPN
M12			
	BU : Blue BN : Brown BK : Black		

See connection on page 9/45.

Setting-up

Minimum mounting distances (mm)

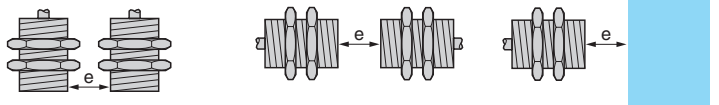

	Side by side	Face to face	Facing a metal object
Ø 8	e ≥ 5	e ≥ 30	e ≥ 8
Ø 12	e ≥ 8	e ≥ 50	e ≥ 12
Ø 18	e ≥ 16	e ≥ 100	e ≥ 25
Ø 30	e ≥ 30	e ≥ 180	e ≥ 45

Dimensions

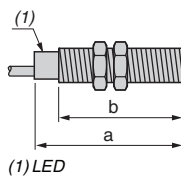

XS6	Pre-cabled (mm)		Connector (mm)	
	a	b	a	b
Ø 8	50	42	61	40
Ø 12	50	42	61	42
Ø 18	60	51	72.2	51
Ø 30	60	51	72.2	51

Inductive proximity sensors

Osiprox® Universal
Cylindrical, flush mountable
Two-wire, a.c. or d.c. supply ⁽¹⁾

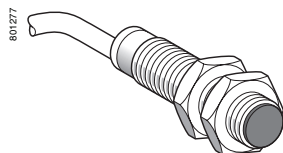

XS6 ●●B1M●L2

2

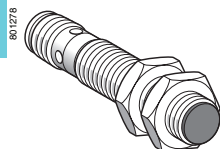

XS6 ●●B1M●U20

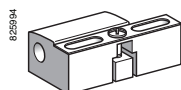

XSZ B1●●

Ø 12, threaded M12 x 1

Sensing distance (Sn) mm	Function	Connection	Reference	Weight kg
4	NO	Pre-cabled (L = 2 m) (2)	XS6 12B1MAL2	0.075
		Connector 1/2" - 20UNF	XS6 12B1MAU20	0.025
	NC	Pre-cabled (L = 2 m) (2)	XS6 12B1MBL2	0.075
		Connector 1/2" - 20UNF	XS6 12B1MBU20	0.025

Ø 18, threaded M18 x 1

Sensing distance (Sn) mm	Function	Connection	Reference	Weight kg
8	NO	Pre-cabled (L = 2 m) (2)	XS6 18B1MAL2	0.120
		Connector 1/2" - 20UNF	XS6 18B1MAU20	0.060
	NC	Pre-cabled (L = 2 m) (2)	XS6 18B1MBL2	0.120
		Connector 1/2" - 20UNF	XS6 18B1MBU20	0.060

Ø 30, threaded M30 x 1.5

Sensing distance (Sn) mm	Function	Connection	Reference	Weight kg
15	NO	Pre-cabled (L = 2 m) (2)	XS6 30B1MAL2	0.205
		Connector 1/2" - 20UNF	XS6 30B1MAU20	0.145
	NC	Pre-cabled (L = 2 m) (2)	XS6 30B1MBL2	0.205
		Connector 1/2" - 20UNF	XS6 30B1MBU20	0.145

Accessories ⁽³⁾

Description		Reference	Weight kg
Fixing clamps	Ø 12	XSZ B112	0.006
	Ø 18	XSZ B118	0.010
	Ø 30	XSZ B130	0.020

⁽¹⁾ Available in Ø8 plastic with double insulation, see page 2/42.

⁽²⁾ For a 5 m long cable, replace L2 with L5, and for a 10 m long cable, replace L2 with L10.

Example: XS6 12B1MAL2 becomes XS6 12B1MAL5 with a 5 m long cable.

⁽³⁾ For further information, see page 2/102.

Inductive proximity sensors

Osiprox® Universal
Cylindrical, flush mountable
Two-wire, a.c. or d.c. supply

Characteristics		XS6 ●●B1M●U20	XS6 ●●B1M●L2
Sensor type		UL, CSA, C€	
Product certifications		UL, CSA, C€	
Connection	Connector	1/2" - 20 UNF	–
	Pre-cabled	–	Length: 2 m
Operating zone	Ø 12	mm 0...3.2	
	Ø 18	mm 0...6.4	
	Ø 30	mm 0...12	
Differential travel	%	1...15 of real sensing distance (Sr)	
Degree of protection	Conforming to IEC 60529	IP 67	IP 68 double insulation ☐
Storage temperature range		°C - 40...+ 85	
Operating temperature range		°C - 25...+ 70	
Materials	Case	Nickel plated brass	
	Pre-cabled	–	PvR 2 x 0.34 mm ²
Vibration resistance	Conforming to IEC 60068-2-6	25 gn, amplitude ± 2 mm (f = 10 to 55 Hz)	
Shock resistance	Conforming to IEC 60068-2-27	50 gn, duration 11 ms	
Output state indication		LED (yellow): 4 viewing ports at 90°	LED (yellow): annular
Rated supply voltage		V ~ or = 24...240 (~ 50/60 Hz)	
Voltage limits (including ripple)		V ~ or = 20...264	
Switching capacity	XS6 12B1M●●●	mA 5...200 (1)	
	XS6 18B1M●●●, XS6 30B1M●●●	mA ~ 5...300 or = 5...200 (1)	
Voltage drop, closed state		V ≤ 5.5	
Residual current, open state		mA ≤ 0.8	
Maximum switching frequency	XS6 12B2●●●, XS6 18B1M●●●	Hz ~ 25 or = 1000	
	XS6 30B1M●●●	Hz ~ 25 or = 500	
Delays	First-up	ms ≤ 20 for XS6 12B1M●●●, ≤ 25 for XS6 18B1M●●● and XS6 30B1M●●●	
	Response	ms ≤ 0.5	
	Recovery	ms ≤ 0.2 for XS6 12B1M●●●, ≤ 0.5 for XS6 18B1M●●●, ≤ 2 for XS6 30B1M●●●	

(1) It is essential to connect a 0.4 A quick-blow fuse in series with the load

Wiring scheme

Connector	Pre-cabled	2-wire ~ or =
1/2" - 20 UNF	BU: Blue BN: Brown	N/O or N/C output
See connection on page 9/45.		⚡: on connector models only

Setting-up

Minimum mounting distances (mm)

	Side by side	Face to face	Facing a metal object
Ø 12	e ≥ 8	e ≥ 50	e ≥ 12
Ø 18	e ≥ 16	e ≥ 90	e ≥ 25
Ø 30	e ≥ 30	e ≥ 180	e ≥ 45

Dimensions

XS6

(1) LED

XS6	Pre-cabled (mm)		Connector (mm)	
	a	b	a	b
Ø 12	50	42	61	42
Ø 18	60	51	72.2	51
Ø 30	60	51	72.2	51

Inductive proximity sensors

Osiprox® Universal

Cylindrical, non flush mountable

Three-wire, d.c. supply, solid-state output

2

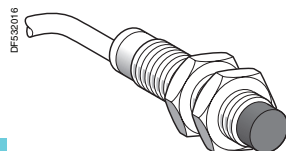

XS6 ●●B4●●L2

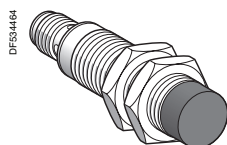

XS6 ●●B4●●M12

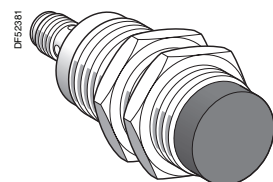

XS6 ●●B4●●M12

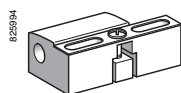

XSZ B●●●

Ø 12, threaded M12 x 1

Sensing dist. (Sn) mm	Function	Output	Connection	Reference	Weight kg
7	NO	PNP	Pre-cabled (L = 2 m) (1)	XS6 12B4PAL2	0.075
			M12 connector	XS6 12B4PAM12	0.020
	NPN	PNP	Pre-cabled (L = 2 m) (1)	XS6 12B4NAL2	0.075
			M12 connector	XS6 12B4NAM12	0.020
	NC	PNP	Pre-cabled (L = 2 m) (1)	XS6 12B4PBL2	0.075
			M12 connector	XS6 12B4PBM12	0.020
NPN	PNP	Pre-cabled (L = 2 m) (1)	XS6 12B4NBL2	0.075	
		M12 connector	XS6 12B4NBM12	0.020	

Ø 18, threaded M18 x 1

Sensing dist. (Sn) mm	Function	Output	Connection	Reference	Weight kg
12	NO	PNP	Pre-cabled (L = 2 m) (1)	XS6 18B4PAL2	0.100
			M12 connector	XS6 18B4PAM12	0.040
	NPN	PNP	Pre-cabled (L = 2 m) (1)	XS6 18B4NAL2	0.100
			M12 connector	XS6 18B4NAM12	0.040
	NC	PNP	Pre-cabled (L = 2 m) (1)	XS6 18B4PBL2	0.100
			M12 connector	XS6 18B4PBM12	0.040
NPN	PNP	Pre-cabled (L = 2 m) (1)	XS6 18B4NBL2	0.100	
		M12 connector	XS6 18B4NBM12	0.040	

Ø 30, threaded M30 x 1.5

Sensing dist. (Sn) mm	Function	Output	Connection	Reference	Weight kg
22	NO	PNP	Pre-cabled (L = 2 m) (1)	XS6 30B4PAL2	0.205
			M12 connector	XS6 30B4PAM12	0.145
	NPN	PNP	Pre-cabled (L = 2 m) (1)	XS6 30B4NAL2	0.205
			M12 connector	XS6 30B4NAM12	0.145
	NC	PNP	Pre-cabled (L = 2 m) (1)	XS6 30B4PBL2	0.205
			M12 connector	XS6 30B4PBM12	0.145
NPN	PNP	Pre-cabled (L = 2 m) (1)	XS6 30B4NBL2	0.205	
		M12 connector	XS6 30B4NBM12	0.145	

Accessories (2)

Description		Reference	Weight kg
Fixing clamps	Ø 12	XSZ B112	0.006
	Ø 18	XSZ B118	0.010
	Ø 30	XSZ B130	0.020

(1) For a 5 m long cable replace L2 by L5; for a 10 m long cable replace L2 by L10.

Example: **XS6 12B4PAL2** becomes **XS6 12B4PAL5** with a 5 m long cable.

(2) For further information, see page 2/102.

Inductive proximity sensors

Osiprox® Universal

Cylindrical, non flush mountable

Three-wire, d.c. supply, solid-state output

Characteristics		XS6 ●●B4●●M12	XS6 ●●B4●●L2
Sensor type		UL, CSA, C€	
Product certifications/approvals		UL, CSA, C€	
Connection	Connector	M12	–
	Pre-cabled	–	Length: 2 m
Operating zone	Ø 12	mm	0...5.6
	Ø 18	mm	0...9.6
	Ø 30	mm	0...17.6
Differential travel		%	1...15 of real sensing distance (Sr)
Degree of protection	Conforming to IEC 60529	IP 67	IP 68, double insulation □
Storage temperature		°C	- 40...+ 85
Operating temperature		°C	- 25...+ 70
Materials	Case	Nickel plated brass	
	Cable	–	PvR, 3 x 0.34 mm ²
Vibration resistance	Conforming to IEC 60068-2-6	25 gn, amplitude ± 2 mm (f = 10 to 55 Hz)	
Shock resistance	Conforming to IEC 60068-2-27	50 gn, duration 11 ms	
Output state indication		Yellow LED: 4 viewing ports at 90°	Yellow LED: annular
Rated supply voltage		V	– 12...48 with protection against reverse polarity
Voltage limits (including ripple)		V	– 10...58
Switching capacity		mA	≤ 200 with overload and short-circuit protection
Voltage drop, closed state		V	≤ 2
Current consumption, no-load		mA	≤ 10
Maximum switching frequency	XS6 12B4●●●●	Hz	2500
	XS6 18B4●●●●	Hz	1000
	XS6 30B4●●●●	Hz	500
Delays	First-up	ms	≤ 10
	Response	ms	≤ 0.2 Ø12, ≤ 0.3 Ø18, ≤ 0.6 Ø30
	Recovery	ms	≤ 0.2 Ø12, ≤ 0.7 Ø18, ≤ 1.4 Ø30

Wiring schemes

Connector	Pre-cabled	PNP	NPN
M12 4 3 1 2	BU: Blue BN: Brown BK: Black		

See connection on page 9/45.

Setting-up

Minimum mounting distances (mm)

	Side by side	Face to face	Facing a metal object
Ø 12	e ≥ 48	e ≥ 84	e ≥ 21
Ø 18	e ≥ 72	e ≥ 144	e ≥ 36
Ø 30	e ≥ 120	e ≥ 264	e ≥ 66

Dimensions

XS6	Pre-cabled (mm)		Connector (mm)		
	a	b	a	b	c
Ø 12	55	41.5	65.5	41.5	5
Ø 18	60	43.5	71.5	43.5	8
Ø 30	62.5	41	74	41	13

(1) LED

Inductive proximity sensors

Osiprox® Universal
Cylindrical, non flush mountable
Two-wire, a.c. or d.c. supply

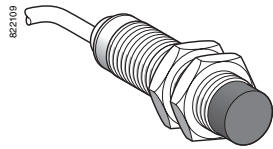

XS6 ●●B4M●L2

2

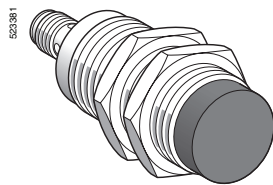

XS6 ●●B4M●U20

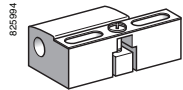

XSZ B1●●

Ø 18, threaded M18 x 1

Sensing distance (Sn) mm	Function	Connection	Reference	Weight kg
12	NO	Pre-cabled (L = 2 m) (1)	XS6 18B4MAL2	0.120
		1/2" - 20UNF connector	XS6 18B4MAU20	0.060
	NC	Pre-cabled (L = 2 m) (1)	XS6 18B4MBL2	0.120
		1/2" - 20UNF connector	XS6 18B4MBU20	0.060

Ø 30, threaded M30 x 1.5

Sensing distance (Sn) mm	Function	Connection	Reference	Weight kg
22	NO	Pre-cabled (L = 2 m) (1)	XS6 30B4MAL2	0.205
		1/2" - 20UNF connector	XS6 30B4MAU20	0.145
	NC	Pre-cabled (L = 2 m) (1)	XS6 30B4MBL2	0.205
		1/2" - 20UNF connector	XS6 30B4MBU20	0.145

Accessories (2)

Description		Reference	Weight kg
Fixing clamps	Ø 18	XSZ B118	0.010
	Ø 30	XSZ B130	0.020

(1) For a 5 m long cable replace L2 by L5; for a 10 m long cable replace L2 by L10.
Example: **XS6 18B4MAL2** becomes **XS6 18B4MAL5** with a 5 m long cable.

(2) For further information, see page 2/102.

Inductive proximity sensors

Osiprox® Universal
Cylindrical, non flush mountable
Two-wire, a.c. or d.c. supply

Characteristics		XS6 ●●B4M●U20	XS6 ●●B4M●L2
Sensor type		XS6 ●●B4M●U20	XS6 ●●B4M●L2
Product certifications/approvals		UL, CSA, C€	
Connection	Connector	1/2" - 20UNF	–
	Pre-cabled	–	Length: 2 m
Operating zone	∅ 18	mm 0...9.6	
	∅ 30	mm 0...17.6	
Differential travel		% 1...15 of real sensing distance (Sr)	
Degree of protection	Conforming to IEC 60529	IP 67	IP 68, double insulation □
Storage temperature		°C - 40...+ 85	
Operating temperature		°C - 25...+ 70	
Materials	Case	Nickel plated brass	
	Cable	–	PvR, 2 x 0.34 mm ²
Vibration resistance	Conforming to IEC 60068-2-6	25 gn, amplitude ± 2 mm (f = 10 to 55 Hz)	
Shock resistance	Conforming to IEC 60068-2-27	50 gn, duration 11 ms	
Output state indication		Yellow LED: 4 viewing ports at 90°	Yellow LED: annular
Rated supply voltage		V ~ or = 24...240 (~ 50/60 Hz)	
Voltage limits (including ripple)		V ~ or = 20...264	
Switching capacity		mA ~ 5...300 or = 5...200 (1)	
Voltage drop, closed state		V ≤ 5.5	
Residual current, open state		mA ≤ 0.8	
Maximum switching frequency	XS6 18B4M●●●	Hz ~ 25 or = 1000	
	XS6 30B4M●●●	Hz ~ 25 or = 300	
Delays	First-up	ms ≤ 30 XS6 18B4M●●● and XS6 30B4M●●●	
	Response	ms ≤ 0.5	
	Recovery	ms ≤ 0.5 XS6 18B4M●●●, ≤ 2 XS6 30B4M●●●	

(1) It is essential to connect a 0.4 A "quick-blow" fuse in series with the load.

Wiring schemes

Connector	Pre-cabled	2-wire ~ or =
1/2" - 20UNF	BU: Blue BN: Brown	NO output
AC/DC : 2 ⊥ : 1 AC/DC : 3		⊥: on connector models only

See connection on page 9/45

Setting-up

Minimum mounting distances (mm)

	Side by side	Face to face	Facing a metal object
∅ 18	e ≥ 72	e ≥ 144	e ≥ 36
∅ 30	e ≥ 120	e ≥ 264	e ≥ 66

Dimensions

XS6

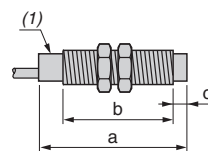

(1) LED

XS6	Pre-cabled (mm)		Connector (mm)		
	a	b	a	b	c
∅ 18	60	43.5	71.5	43.5	8
∅ 30	62.5	41	74	41	13

Inductive proximity sensors

Osiprox® Universal, Osiconcept® (1)

Flat, flush mountable and non flush mountable, forms E, C and D

Two-wire, a.c. or d.c. supply

Three-wire, d.c. supply, solid-state output

2

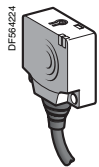

XS8 E1A1●●L2

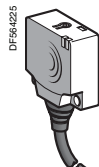
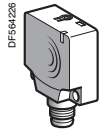
XS8 ●1A1●●L01M12
XS8 ●1A1●●L01U20

XS8 E1A1●●M8

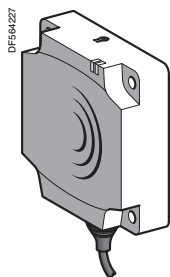

XS8 C1A1●●L2

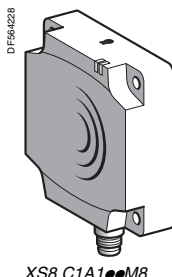

XS8 C1A1●●M8

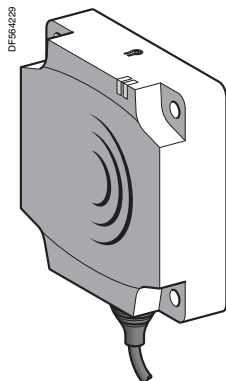

XS8 D1A1●●L2

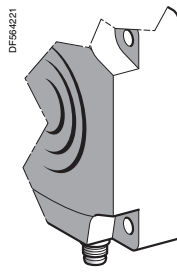

XS8 D1A1●●M12

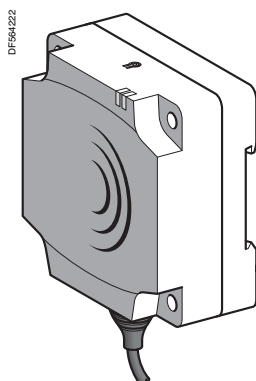

XS8 D1A1●●L2DIN

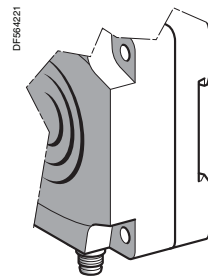

XS8 D1A1●●M12DIN

Flat, form E, 26 x 26 x 13 mm (2)

Sensing dist. (Sn) mm	Function	Output	Connection	Reference	Weight kg
Three-wire \equiv with overload and short-circuit protection					
15	NO	PNP	Pre-cabled (L = 2 m) (3)	XS8 E1A1PAL2	0.075
			M8 connector	XS8 E1A1PAM8	0.040
			Remote M12 connector	XS8 E1A1PAL01M12	0.040
	NPN	Pre-cabled (L = 2 m) (3)	XS8 E1A1NAL2	0.075	
		M8 connector	XS8 E1A1NAM8	0.040	
		Remote M12 connector	XS8 E1A1NAL01M12	0.040	
NC	PNP	Pre-cabled (L = 2 m) (3)	XS8 E1A1PBL2	0.075	
		M8 connector	XS8 E1A1PBM8	0.040	
		Remote M12 connector	XS8 E1A1PBL01M12	0.040	
NPN	Pre-cabled (L = 2 m) (3)	XS8 E1A1NBL2	0.075		
	M8 connector	XS8 E1A1NBM8	0.040		
	Remote M12 connector	XS8 E1A1NBL01M12	0.040		

Two-wire \sim or \equiv unprotected (4)

15	NO	-	Pre-cabled (L = 2 m) (3)	XS8 E1A1MAL2	0.070
			Remote 1/2" - 20 UNF connec.	XS8 E1A1MAL01U20	0.040
NC	-	-	Pre-cabled (L = 2 m) (3)	XS8 E1A1MBL2	0.070
			Remote 1/2" - 20 UNF connec.	XS8 E1A1MBL01U20	0.040

Flat, form C, 40 x 40 x 15 mm (2)

Sensing dist. (Sn) mm	Function	Output	Connection	Reference	Weight kg
Three-wire \equiv with overload and short-circuit protection					
25	NO	PNP	Pre-cabled (L = 2 m) (3)	XS8 C1A1PAL2	0.095
			M8 connector	XS8 C1A1PAM8	0.060
			Remote M12 connector	XS8 C1A1PAL01M12	0.060
	NPN	Pre-cabled (L = 2 m) (3)	XS8 C1A1NAL2	0.095	
		M8 connector	XS8 C1A1NAM8	0.060	
		Remote M12 connector	XS8 C1A1NAL01M12	0.060	
NC	PNP	Pre-cabled (L = 2 m) (3)	XS8 C1A1PBL2	0.095	
		M8 connector	XS8 C1A1PBM8	0.060	
		Remote M12 connector	XS8 C1A1PBL01M12	0.060	
NPN	Pre-cabled (L = 2 m) (3)	XS8 C1A1NBL2	0.095		
	M8 connector	XS8 C1A1NBM8	0.060		
	Remote M12 connector	XS8 C1A1NBL01M12	0.060		

Two-wire \sim or \equiv unprotected (4)

25	NO	-	Pre-cabled (L = 2 m) (3)	XS8 C1A1MAL2	0.090
			Remote 1/2" - 20 UNF connec.	XS8 C1A1MAL01U20	0.060
NC	-	-	Pre-cabled (L = 2 m) (3)	XS8 C1A1MBL2	0.090
			Remote 1/2" - 20 UNF connec.	XS8 C1A1MBL01U20	0.060

Flat, form D, 80 x 80 x 26 mm (2)

Sensing dist. (Sn) mm	Function	Output	Connection	Reference	Weight kg
Three-wire \equiv with overload and short-circuit protection					
60	NO	PNP	Pre-cabled (L = 2 m) (3)	XS8 D1A1PAL2 (5)	0.390
			M12 connector	XS8 D1A1PAM12 (5)	0.340
			Remote M12 connector	XS8 D1A1PAL2 (5)	0.390
	NPN	Pre-cabled (L = 2 m) (3)	XS8 D1A1NAL2 (5)	0.390	
		M12 connector	XS8 D1A1NAM12 (5)	0.340	
		Remote M12 connector	XS8 D1A1NAL2 (5)	0.390	
NC	PNP	Pre-cabled (L = 2 m) (3)	XS8 D1A1PBL2 (5)	0.390	
		M12 connector	XS8 D1A1PBM12 (5)	0.340	
		Remote M12 connector	XS8 D1A1PBL2 (5)	0.390	
NPN	Pre-cabled (L = 2 m) (3)	XS8 D1A1NBL2 (5)	0.390		
	M12 connector	XS8 D1A1NBM12 (5)	0.340		
	Remote M12 connector	XS8 D1A1NBL2 (5)	0.390		
Two-wire \sim or \equiv unprotected (4)					
60	NO	-	Pre-cabled (L = 2 m) (3)	XS8 D1A1MAL2 (5)	0.390
			1/2" - 20 UNF connector	XS8 D1A1MAU20 (5)	0.340
NC	-	-	Pre-cabled (L = 2 m) (3)	XS8 D1A1MBL2 (5)	0.390
			1/2" - 20 UNF connector	XS8 D1A1MBU20 (5)	0.340

(1) For further information on Osiconcept®, see page 2/20

(2) For accessories, see page 2/102.

(3) For a 5 m long cable, replace L2 with L5, and for a 10 m long cable, replace L2 with L10.

(4) It is essential to connect a 0.4 A quick-blow fuse in series with the load.

(5) For clipping onto 35 mm omega rail or 80 x 80 x 40 mm format, add DIN to the end of the reference. Example: XS8 D1A1PAL2 DIN.

Inductive proximity sensors

Osiprox® Universal, Osiconcept® (1)

Flat, flush mountable and non flush mountable, forms E, C and D

Two-wire, a.c. or d.c. supply

Three-wire, d.c. supply, solid-state output

Characteristics		XS8 E●●●●●M8, XS8 C●●●●●M8, XS8 D●●●●●M12, XS8 D●●●●●U20	XS8 E●●●●●L01M12, XS8 E●●●●●L01U20, XS8 C●●●●●L01M12, XS8 C●●●●●L01U20	XS8 E●●●●●L2, XS8 C●●●●●L2, XS8 D●●●●●L2
Product certifications		UL, CSA, C€		
Connection	Connector	M8 except XS8 ●●●●●M12: M12 XS8 ●●●●●U20: 1/2" 20UNF	0.15 m flying lead with remote connec. XS8 ●●●●●L01M12: M12, XS8 ●●●●●L01U20: 1/2" 20UNF	–
	Pre-cabled	–	–	Length: 2 m
Sensing distance and adjustment zone	XS8 E	Nominal sensing dist. Sn	mm 0...15 non flush mounted configuration / 0...10 flush mounted configuration	
		Fine adjustment zone	mm 5...15 non flush mounted configuration / 5...10 flush mounted configuration	
	XS8 C	Nominal sensing dist. Sn	mm 0...25 non flush mounted configuration / 0...15 flush mounted configuration	
		Fine adjustment zone	mm 8...25 non flush mounted configuration / 8...15 flush mounted configuration	
XS8 D	Nominal sensing dist. Sn	mm 0...60 non flush mounted configuration / 0...40 flush mounted configuration		
	Fine adjustment zone	mm 20...60 non flush mounted configuration / 20...40 flush mounted configuration		
Differential travel		% 1...15 of real sensing distance (Sr)		
Degree of protection	Conforming to IEC 60529	IP 67 double insulation □ (except for M8 connector: IP 67)		IP 68 □
Storage temperature range		°C - 40...+ 85		
Operating temperature range		°C - 25...+ 70		
Materials	Case	PBT		
	Pre-cabled	–	PvR 3 x 0.34 mm ² ∞ and PvR 2 x 0.34 mm ² ∞	
Vibration resistance	Conforming to IEC 60068-2-6	25 gn, amplitude ± 2 mm (f = 10 to 55 Hz)		
Shock resistance	Conforming to IEC 60068-2-27	50 gn, duration 11 ms		
Indicator	Output state	Yellow LED		
	Supply on and teach mode	Green LED		
Rated supply voltage	3-wire	V 12...24 with protection against reverse polarity		
	2-wire	V ~ or ∞ 24...240 (~ 50/60 Hz)		
Voltage limits (including ripple)	3-wire	V 10...36		
	2-wire	V ~ or ∞ 20...264		
Current consumption, no-load	3-wire	mA ≤ 10		
Residual current, open state	2-wire	mA ≤ 1.5		
Switching capacity	3-wire	mA ≤ 100 XS8 E, ≤ 200 XS8 C and XS8 D, with overload and short-circuit protection		
	2-wire	mA 5...200 ≈ XS8 E, 5...300 ~ XS8 C and XS8 D, 5...200 ∞ XS8 C and XS8 D.		
Voltage drop, closed state	3-wire	V ≤ 2		
	2-wire	V ≤ 5.5		
Maximum switching frequency		Hz 2000 XS8 E, 1000 XS8 C, 150 XS8 D		
Delays	First-up	ms ≤ 10 XS8 E, XS8 C and XS8 D (3-wire), ≤ 10 XS8 E and XS8 C, ≤ 15 XS8 D (2-wire)		
	Response	ms ≤ 0.3		
	Recovery	ms ≤ 0.8 XS8 E and XS8 C, ≤ 6 XS8 D		

Wiring scheme

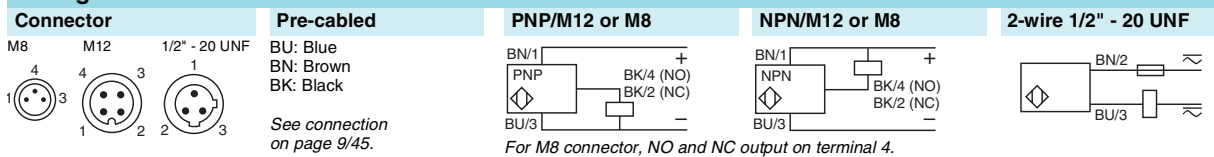

Setting-up

Minimum mounting distances (mm)		e ≥	XS8 E	XS8 C	XS8 D
Side by side	Flush mounted	40	60	200	
	Non flush mounted	150	125	600	
Face to face	Flush mounted	80	120	400	
	Non flush mounted	300	250	Not recommended	
Facing a metal object		e ≥	XS8 E	XS8 C	XS8 D
			10	15	40

Dimensions

Sensor	A (cable)	A (connector)	B	C	D	E	F	G	H
XS8 E	14	11	26	13	8,8	20	3,5	6.8	6.6
XS8 C	14	11	40	15	9,8	33	4,5	8.3	13.6
XS8 D	23	18	80	26	16	65	5,5	8.5	37.8
XS8 D●●DIN	23	18	80	40	30	65	5.1	22.5	37.8

(1) For further information on Osiconcept®, see page 2/20