



## PowerLogic PM700 Power and energy meters

Cost-effective, compact meter for basic measurements, signed PF, THD, digital I/O and alarms.



## Compact, cost-effective power and energy meters

PowerLogic PM700 series power and energy meters offer outstanding quality, versatility and functionality in a cost-effective, ultra-compact unit. OEMs, panel builders and customers in industrial, buildings or infrastructure environments will find the meters ideal for replacing analog meters or for adding metering to custom panels, switchboards, switchgear, gensets, motor control centers and UPS systems. The meters are simple to use and offer large, bright LCD displays. They can be used for stand-alone metering or seamlessly integrated with PowerLogic power and energy management systems.

The meters are available in four models with incremental features. All models offer power, demand, energy, power factor, frequency and THD measurements, with higher models offering a choice of digital inputs, outputs, RS-485 communications and alarm functions. Perfect for monitoring right down to the tool level, the meters' IEC Class 1 or Class 0.5 certified accuracy make them suited for many applications.

## Typical applications

- Energy savings
  - Measure efficiency, reveal opportunities and verify savings
  - Sub-bill tenants for energy costs
  - Allocate energy costs to departments or processes
  - Reduce peak demand surcharges
  - Reduce power factor penalties
  - Leverage existing infrastructure capacity and avoid over-building
  
- Energy availability and reliability
  - Verify the reliable operation of equipment
  - Improve response to power quality-related problems

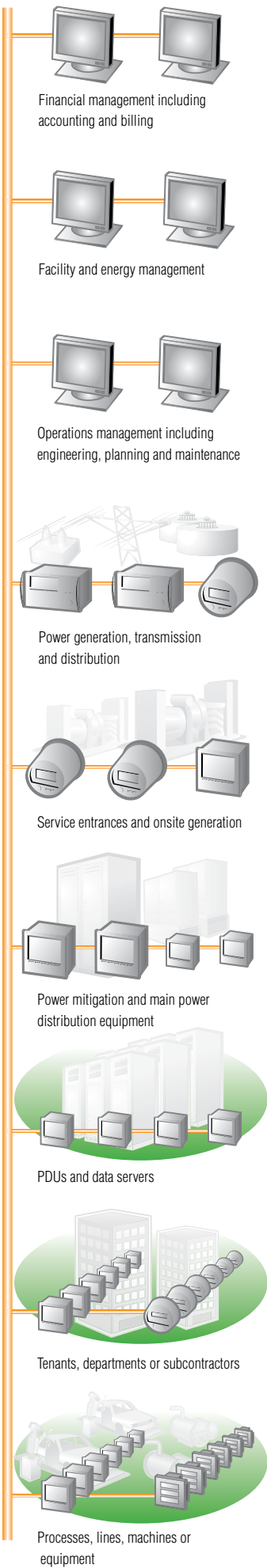

Financial management including accounting and billing

Facility and energy management

Operations management including engineering, planning and maintenance

Power generation, transmission and distribution

Service entrances and onsite generation

Power mitigation and main power distribution equipment

PDU's and data servers

Tenants, departments or subcontractors

Processes, lines, machines or equipment

## Features

### Cost-effective

- Simple retrofit
- Low initial investment

### Ease of use

- Fast setup via display or software
- Compatible with entry-level PowerView software
- Bright, easy to read LCD display

### High accuracy metering

- IEC62053-22 Class 0.5S energy accuracy (PM750)
- IEC62053-21 Class 1 energy accuracy (PM700, PM700P, PM710)

### Communications

- RS-485 port (PM710, PM750)
- Modbus protocol for integration with power and energy management software such as PowerLogic ION Enterprise, PowerLogic System Manager or PowerLogic PowerView

### Pulse inputs and outputs

- 2 outputs (PM700P) for kWh or kvarh pulsing
- 1 output (PM750) for kWh-pulsing, alarm status or external controlled output
- 2 inputs (PM750) for status, alarms or demand input synchronisation



PM700 series meter front view showing integrated display.



PM700 series meter rear view showing connectors.

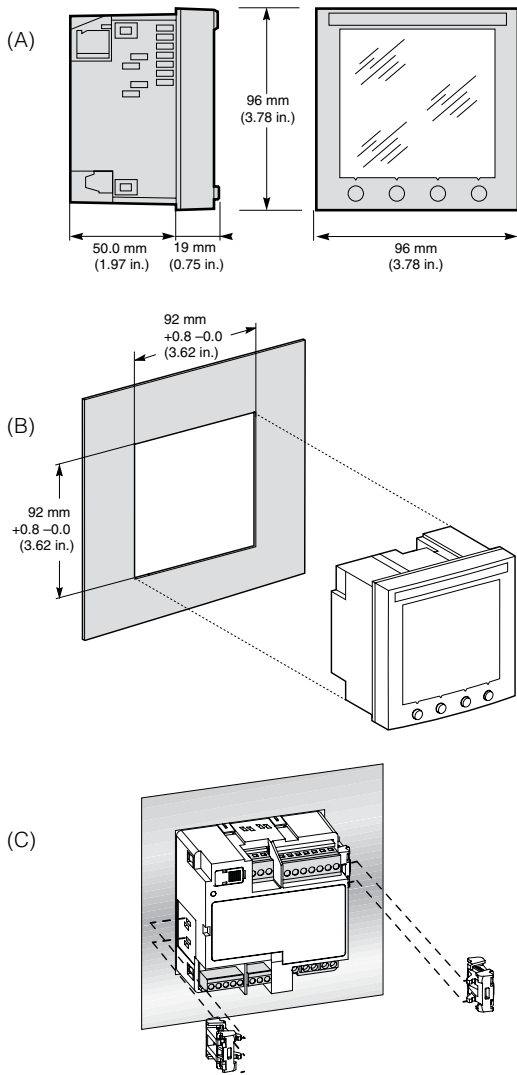

- A. Meter dimensions, showing depth behind panel, and display bezel side and front dimensions.
- B. Meter mounted into square panel cutout.
- C. Mounting clips securing meter behind panel.

## Installation

### Mounting Options

The meters come with an integrated display and can be quickly panel mounted through a square cutout using two clips with no tools required. A small panel footprint and shallow 50 mm (1.97 in.) depth behind the mounting surface maximises free space for other electrical devices inside a switchgear cabinet when mounted on the door. This makes the meters suitable for low voltage switchboards, shallow cable compartments or on standalone machines.

### Circuit and control power connections

All models are compatible with low and high voltage 4-wire wye and 3-wire delta systems and are suitable for three-phase (3P, 3P + N), two-phase and single-phase systems. Direct connect inputs up to 480 V ac line-to-line or use voltage (potential) transformers for higher voltage systems. All models offer a universal AC or DC power supply.

Input(s)	Specifications
<b>Voltage inputs</b>	
Nominal full scale (Un):	10 to 277 direct V ac line-to-neutral 10 to 480 V ac direct line-to-line Up to 1.6 MV with external VT/PT, start of measuring voltage depends on PT ratio
Metering over-range	1.2 Un (20%)
Input impedance	2 M Ω (Ph-Ph) / 1 M Ω (Ph-N)
Frequency range	45 to 65 Hz
<b>Current inputs</b>	
Nominal current	1 A or 5 A ac
Metering range	5 mA to 6 A ac
Withstand	10 A continuous, 50 A for 10 s per hour, 120 A for 1 s per hour
Load/burden	< 0.15 VA
Impedance	< 0.1 ohm
<b>Control power</b>	
Operating range	100 to 415 V ac ±10% 125 to 250 V dc ±20%
Load/burden	5 VA (ac) or 3 W (dc)
Ride through	100 ms at 120 V ac

## Front panel display

The anti-glare backlit green LCD is easily read in extreme lighting conditions or viewing angles. An intuitive navigation with self-guided menus make the meter easy to use. The large 6-line display offers summary screens that simultaneously present up to 4 concurrent values, including power and energy values, I/O conditions or alarm status. Bar chart displays graphically represent system loading and I/O conditions. Historical and active alarms include timestamps.

## Communications

Model PM710 and PM750 meters offer a standard RS-485 communication port that allows data to be uploaded to software for viewing and analysis. **The port offers** 2-wire connection, operates at speeds up to 19.2 kbaud, and supports Modbus RTU protocol.

## Software integration

Model PM710 and PM750 meters are compatible with PowerLogic facility-level or enterprise-wide power and energy management systems. Real-time and min/max data can be automatically retrieved for analysis at the system level. Compatible with PowerLogic ION Enterprise, PowerLogic System Manager, PowerLogic PowerView and PowerLogic Tenant Metering software. Modbus compatibility supports integration with building automation, SCADA and other third-party systems.

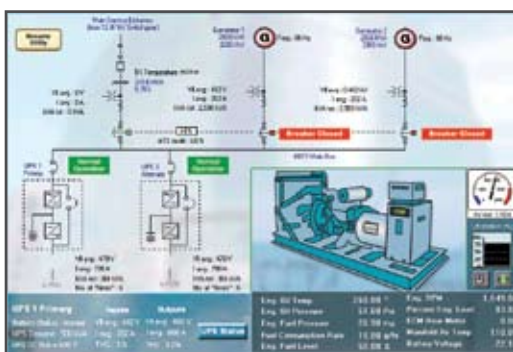

Example screen from PowerLogic ION Enterprise software showing electrical system diagram with multiple real-time metering points.

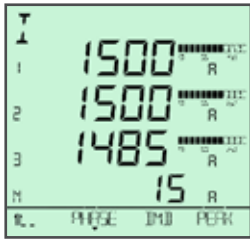

3-phase and neutral current display

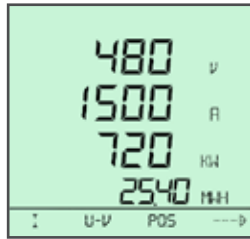

Voltage, current, power summary display

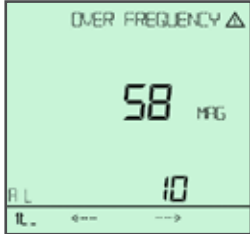

Alarm display showing active alarm\*

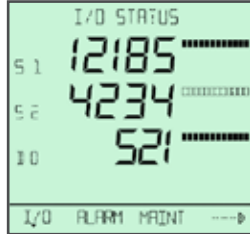

Digital inputs and outputs display\*

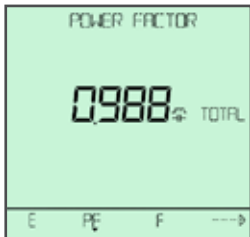

Power factor display\*

\* Available for model PM750 only.

## Power and energy measurements

Metering is performed by zero-blind sampling all inputs at 32 samples/cycle with a data update rate of 1 second. The meter offers a range of instantaneous RMS, power, demand and energy measurements suitable for real-time monitoring, energy management and sub-billing purposes.

Measurement	Accuracy
Current: per phase, neutral, min/max Current demand: present, peak <sup>1</sup>	±0.4% (PM750) ±0.5% (PM700,700P,PM710) from 1 A to 6 A
Voltage (line-line, line-neutral): per phase, min/max	±0.3% (PM750) ±0.5% (PM700, 700P, PM710) from 50 V to 277 V
Power: real (kW), reactive (kvar), apparent (kVA), per-phase, total Power demand: present, peak <sup>1</sup>	±0.5% (PM750) ±1% (PM700, PM700P and PM710)
Energy: real (kWh), reactive (kvarh), apparent (kVAh), in/out (PM750)	Real: Class 1 as defined by IEC 62053-21 (PM700, PM700P, and PM710), Class 0.5S as defined by IEC 62053-22 (PM750) Reactive: Class 2 as defined by IEC 62053-23
Power factor: total, signed (PM750), min/max	±0.0034 for readings from -0.5 to +0.5
Frequency: present, min/max	±0.02 % from 45 to 65 Hz

<sup>1</sup> Selectable block or sliding demand calculation mode with internal or external (via digital input) demand synchronisation.

## Power quality analysis

All models offer total harmonic distortion measurement (THD) on voltage and current, per phase and min/max. The model PM750 can alarm on THD levels.

## Digital inputs and outputs

The model PM700P has two solid-state KY outputs dedicated to kWh and kvarh pulsing. The model PM750 has one digital output three operating modes: external control (default), alarm (control relay in response to alarm condition) and kWh pulse. The PM750 also has two digital inputs featuring two operating modes: normal and demand synchronisation. Use these to trigger alarms or monitor equipment status.

## Alarm and control functions

The PM750 features 15 user-configurable alarms that can be used to trigger on over and under conditions most commonly found in power systems. Get early warning of impending problems that could lead to equipment problems or downtime. Communicate alarms through the RS-485 port for remote monitoring and use the meter's digital outputs for control applications to help avoid penalties and perform proactive maintenance.

### List of inputs and outputs

Type	Input / output	Specifications
PM700P	2 digital KY outputs	3 to 240 V dc or 6 to 240 V ac, 100 mA at 25 °C, derate 0.56 mA per °C above 25 °C, 2.41 kV rms isolation, 30 Ω on-resistance at 100 mA
PM750	1 digital KY output	8 to 36 V dc, 24 V dc nominal at 25 °C, 3.0 kV rms isolation, 28 Ω on-resistance at 100 mA
	2 digital inputs	12 to 36 V dc, 24 V dc nominal, 12 kΩ impedance, 2.5 kV rms isolation, max. frequency 25 Hz, response time 10 ms

## General specifications

Description	Specification
Weight	0.37 kg (0.8 lb)
Safety	Europe: CE as per IEC 61010-1 i (1). USA and Canada: UL508.
Operating temp.	Meter: -5 °C to +60 °C. Display: -10 °C to +50 °C.
Storage temp.	Meter and display: -40 °C to +85 °C
Relative humidity	5 to 95% at 50 °C (non-condensing)
Altitude	3000 m maximum
Pollution degree	2
Installation category	III, for distribution systems up to 277/480 Vac
Dielectric withstand	As per EN 61010, UL508 - double insulated front panel display
IP degree of protection	As per IEC 60529: IP52 front display, IP30 meter body
Immunity	ESD: IEC 61000-4-2 Level 3, Radiated: IEC 61000-4-3 Level 3, Fast transients: IEC 61000-4-4 Level 3, Impulse waves: IEC 61000-4-5 Level 3 Conducted: IEC 61000-4-6 Level 3, Magnetic field: IEC 61000-4-8 Level 3, Voltage dips: IEC 61000-4-11 Level 3
Emissions	Conducted and radiated: CE commercial environment/FCC part 15 class B EN 55011, Harmonics: IEC 61000-3-2, Flicker: IEC 61000-3-3

Selection Guide		PM700	PM700P	PM710	PM750
<b>General</b>					
Use on LV and HV systems		■	■	■	■
Current accuracy (1 A to 6 A)		±0.5 %	±0.5 %	±0.5 %	±0.4 %
Voltage accuracy (50 V to 277 V)		±0.5 %	±0.5 %	±0.5 %	±0.3 %
Energy and power accuracy		1.0 %	1.0 %	1.0 %	0.5 %
<b>Instantaneous rms values</b>					
Current	Phases and neutral	■	■	■	■
Voltage	Ph-Ph, Ph-N	■	■	■	■
Frequency		■	■	■	■
<b>Power<sup>1</sup></b>					
Real		■	■	■	signed
Reactive		■	■	■	signed
Apparent		■	■	■	■
Power factor	Total	■	■	■	signed
<b>Energy values</b>					
Active, reactive, apparent energy		■	■	■	signed <sup>2</sup>
<b>Demand values</b>					
Current (present and max.)		■	■	■	■
Active, reactive, apparent power		■	■	■	■
Setting of calculation mode		■	■	■	■
<b>Power quality measurements</b>					
Harmonic distortion (current, voltage)		■	■	■	■
<b>Data recording</b>					
Min/max of instantaneous values		■	■	■	■
<b>Display and I/O</b>					
Backlit LCD display		■	■	■	■
Pulse output		-	2	-	1
Pulse input		-	-	-	2
<b>Communication</b>					
RS 485 port		-	-	■	■
Modbus protocol		-	-	■	■
<b>Alarms</b>					
Over/under conditions		-	-	-	15

<sup>1</sup> Total and per phase

<sup>2</sup> Real and reactive power and energy are signed net consumptions (PM750)

Please contact your local sales representative for ordering information.

Visit [www.powerlogic.com](http://www.powerlogic.com) for more information on other PowerLogic products, applications and system solutions.

Schneider Electric Industries SAS  
89, boulevard Franklin Roosevelt  
F - 92500 Rueil-Malmaison (France)  
tél : +33 (0)1 41 29 85 00

[www.powerlogic.com](http://www.powerlogic.com)  
[www.schneider-electric.com](http://www.schneider-electric.com)

PLSED106037EN

As standards, specifications and designs develop over time, always ask for confirmation of the information given in this publication. PowerLogic, ION, ION Enterprise and Modbus are either trademarks or registered trademarks of Schneider Electric.



Printed on recycled paper

Publishing : Schneider Electric  
Production : Schneider Electric PMC  
Printing : Imprimerie du Pont de Claix - made in France



"The 2007 award recognizes Schneider Electric for its technological advancements and wide product range in the field of power quality (PQ) and energy management solutions. In total, this is the fourth award that Schneider Electric and [recently acquired] Power Measurement have received from Frost & Sullivan in recognition of achievements in this arena."  
Prithvi Raj, Frost & Sullivan research analyst



Bronze winner, 2007 Product of the Year (PM750), Plant Engineering Magazine

**PowerLogic** **ION**

Power Measurement and its ION products were recently acquired by Schneider Electric and integrated within our PowerLogic range of software and hardware, creating the world's largest line of power and energy management solutions.

